

# DINGLI JCPT1218DC

## SELF PROPELLED SCISSOR LIFT - ELECTRIC



### SPECIFICATIONS

Size	Metric	British
Max. Working Height <b>A</b>	12.00m	39ft 4in
Max. Platform Height <b>B</b>	10.00m	32ft 10in
Overall Length(Without Outriggers)	3.19m	10ft 6in
Overall Length(With Outriggers) <b>C</b>	3.84m	12ft 7in
Overall Width <b>D</b>	1.76m	5ft 9in
Overall Height(Rails Up) <b>E</b>	2.59m	
Overall Height(Rails Down) <b>F</b>	1.82m	6ft
Platform Size(Length×Width)	2.88m×1.52m	9ft 5in × 5ft
Platform Extension Size <b>G</b>	1.43m	4ft 8in
Ground Clearance(Stowed/Raised)	0.24m	9in
Wheelbase <b>H</b>	2.29m	7ft 6in
Turning Radius(Inside/Outside)	2.15m/4.85m	7ft 1in/15ft 11in
Tyres	26×12-16.5	26×12-16.5

Performance		
S.W.L	454kg	1000lb
S.W.L On Extension	136kg	299lb
Max. Occupants	4	4
Gradeability	40%	40%
Travel Speed(Stowed)	6.3km/h	6.3km/h
Travel Speed(Raised)	0.45km/h	0.45km/h
Max. Working Slope	1.5°/3°	1.5°/3°
Up/Down Speed	40/46sec	40/46sec

Weight		
Overall Weight(Without Outriggers)	4135kg	9116lb
Overall Weight(With Outriggers)	4400kg	9700lb

Power		
Hydraulic Tank	71L	71L
Battery	48V/320Ah	48V/320Ah
Charger	48V/35A	48V/35A
Driving Motor	2×32VAC/3.3kW	2×32VAC/3.3kW
Lifting Motor	DC 48V/3.8kW	DC 48V/3.8kW

\* The platform height plus 2m (7ft in British standard) is the working height.  
Standards Compliance

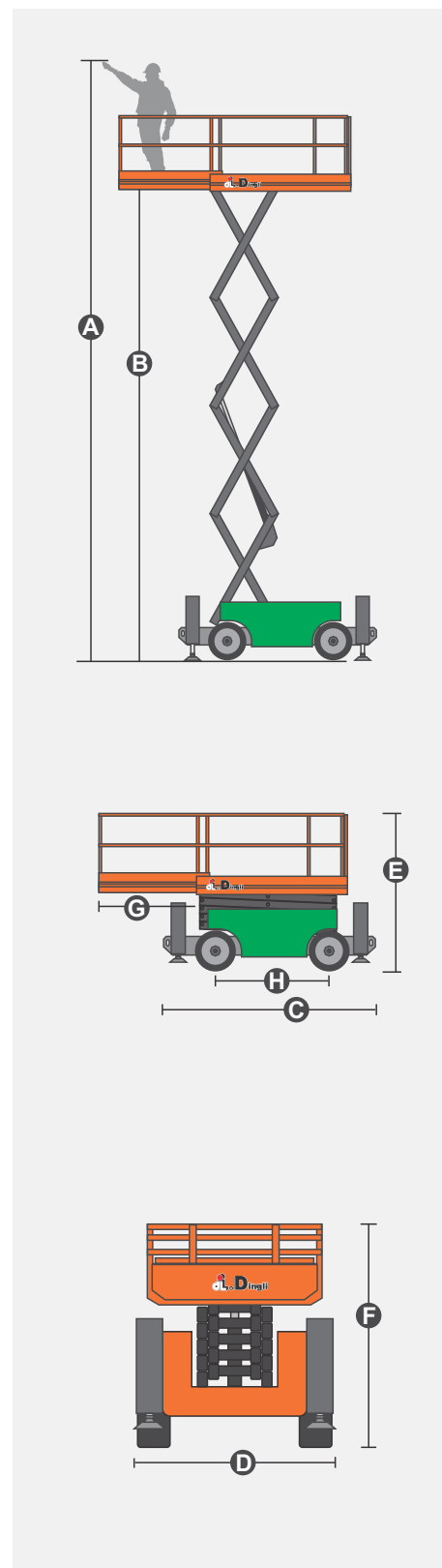

# DINGLI JCPT1218DC

## SELF PROPELLED SCISSOR LIFT - ELECTRIC



### FEATURES

#### Standard Items

- Proportional Joystick Controls
- Self-Locking Gates
- One-Way Platform Extension Deck
- 4x2 Drive
- Four-Wheel Braking
- Emergency Descent System
- Tubing Explosion-Proof System
- Onboard Fault Diagnostic System
- Tilt Alarm
- Motion Alarm
- Horn
- Hour Meter
- Charging Protection System
- Flashing LED Beacon
- Foldable Guard Rails
- Drive Enable
- Automatic One-Way Platform Extension Deck
- Manual Brake Release
- Lanyard Attachment Point
- Standard Transport Forklift Pockets
- Automatic Leveling Hydraulic Outriggers
- Oscillating Axle Chassis
- Emergency Stop Button
- Platform Load Sense System
- Drivable At Full Height

#### Optional Items

##### Factory Tyres

- Foam-Filled Tyres \*\*
- Non-Marking Tyres

##### Factory Hydraulic Oil

- No. 46 Hydraulic Oil (Mineral Oil)\*\*

#### Additional Items

- GPS Unit
- Biodegradable Hydraulic Oil
- AC Power Cord to Platform
- Air Line to Platform
- Work Light Package
- Footpedal Switch
- Anti-Collision Bar on Platform
- Visual Spirit Level
- Outrigger Pad Package