

DINGLI JCPT3214DC

SELF-PROPELLED ROUGH-TERRAIN SCISSOR LIFTS - ELECTRIC



SPECIFICATIONS

Size	Metric	British
Max. Working Height A	32.00m	105ft
Max. Platform Height B	30.00m	98ft 5in
Overall Length C	6.41m	21ft
Overall Width D	1.40m	4ft 7in
Overall Height(Rails Up) E	4.16m	4ft 7in
Overall Height(Rails Down) F	3.17m	10ft 5in
Platform Size(Length×Width)	5.85m×1.2m	19ft 2.3in × 3ft 11in
Platform Extension Size G	1.9m	6ft 3in
Ground Clearance(Stowed/Raised)	0.20m/0.02m	8in/1in
Wheelbase H	4.87m	16ft
Turning Radius(Inside/Outside)	2.6m/3.5m	8ft 6in/11ft 6in
Tyres	28×12-22	28×12-22

Performance		
S.W.L	750kg	1653lb
S.W.L On Extension	750kg	1653lb
Max. Occupants	2	2
Gradeability	30%	30%
Travel Speed(Stowed)	1.4km/h	1.4km/h
Travel Speed(Raised)	0.1km/h	0.1km/h
Max. Working Slope	1°(0°)	1°(0°)
Up/Down Speed	160/105sec	160/105sec

Weight		
Overall Weight	22200kg	48942lb

Power		
Hydraulic Tank	220L	220L
Battery	80V/520Ah	80V/520Ah
Charger	80V/80A	80V/80A
Driving Motor	4×80V/2.0kW	4×80V/2.0kW
Lifting Motor	AC 53V/28kW	AC 53V/28kW

* The platform height plus 2m (7ft in British standard) is the working height.
Standards Compliance

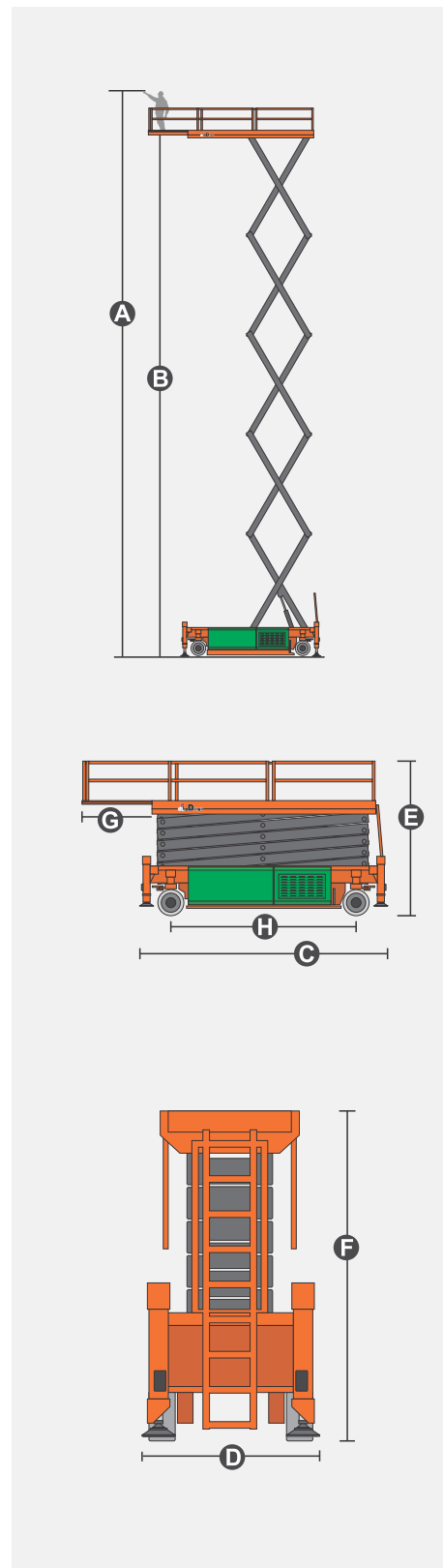

DINGLI JCPT3214DC

SELF-PROPELLED ROUGH-TERRAIN SCISSOR LIFTS - ELECTRIC



FEATURES

Standard Items

- Proportional Joystick Controls
- Self-Locking Gates
- One-Way Platform Extension Deck
- Drivable At Full Height
- Solid Rubber Tyres
- 4x4 Drive
- 4x4 Steer
- Four-Wheel Braking
- Self-Weight Lowering System
- Tubing Explosion-Proof System
- Onboard Fault Diagnostic System
- Tilt Alarm
- Motion Alarm
- Horn
- Hour Meter
- Charging Protection System
- Flashing LED Beacon
- Foldable Guard Rails
- Drive Enable
- Automatic One-Way Platform Extension Deck
- Manual Brake Release
- Lanyard Attachment Point
- Tie-Down And Lifting Points
- Automatic Leveling Hydraulic Outriggers
- Emergency Pump
- Emergency Stop Button
- Platform Load Sense System

Optional Items

Factory Hydraulic Oil

- No. 46 Hydraulic Oil (Mineral Oil)**

Additional Items

- GPS Unit
- Biodegradable Hydraulic Oil
- AC Power Cord to Platform
- Air Line to Platform
- Work Light Package
- Footpedal Switch
- Anti-Collision Bar on Platform
- Visual Spirit Level
- Outrigger Pad Package
- Guard Mesh Package
- Self-Lubrication System