

OMME

MINI 15 EXJ / MINI 15 EXBJ

ARTICULATED SPIDER LIFT-TRAILER MOUNTED



OMME

MINI 15 EXJ / MINI 15 EXBJ

ARTICULATED SPIDER LIFT-TRAILER MOUNTED

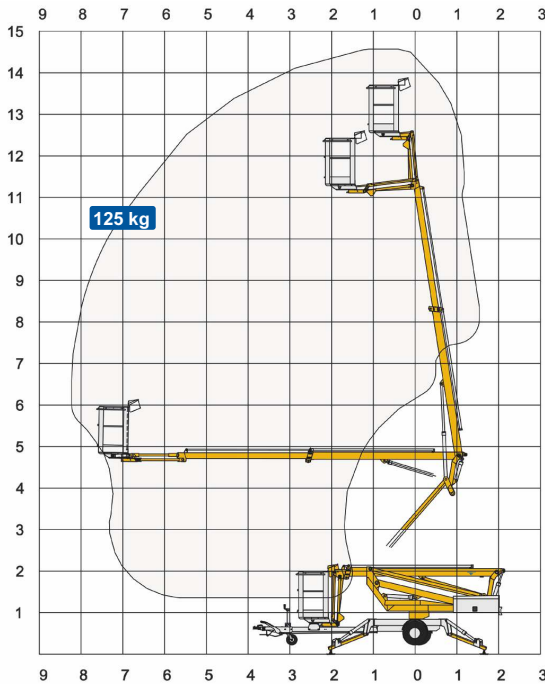

Technical Data:	Mini 15 EXJ	Mini 15 EXBJ
Max. working height	14.6 m	
Max. platform height	12.6 m	
Max. outreach	8.3 m	
Up and over clearance	4.5 m	
Angle boom length (boom + basket)	-	
Jib length (jib + basket)	2.0 m	
Vertical jib rotation	90°	
Turret rotation	± 355°	
Basket rotation	-	
Max. basket load	125 kg	
Basket size	0.85 x 0.7 x 1.1 m	
Stabilizer pad size	ø200 mm	
	230V / 10A	BATTERY
Engine		
Fuel tank capacity		
Generator		
Battery pack	24V/120Ah/5h	
Charger	24 V / 15 A	
Double charger system	Optional	
Elec. descent	Optional	Optional
Self-propulsion with hydraulic engagement of traction rollers	Standard	
Gradeability	14% / 8°	
Ground to tire clearance at max. set-up	Min. 170 mm (7.6% / 4.3°)	
Total weight	1500 kg	1500 kg
Ground pressure, outrigger pad	10.0 kg/cm ²	10.0 kg/cm ²
Ground pressure with 0.4 x 0.4 m spreader plate	0.5 kg/cm ²	0.5 kg/cm ²
Max. force, outrigger	8.5 kN	8.5 kN
Hydraulic stabilizers	Standard	
Controls	2-step	
Flush basket mount	Standard	
Elec. power outlet in basket	Standard	
Tool tray in basket	Standard	

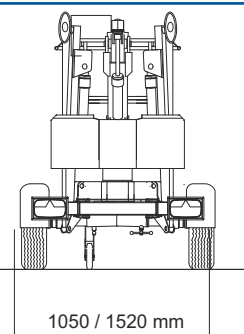
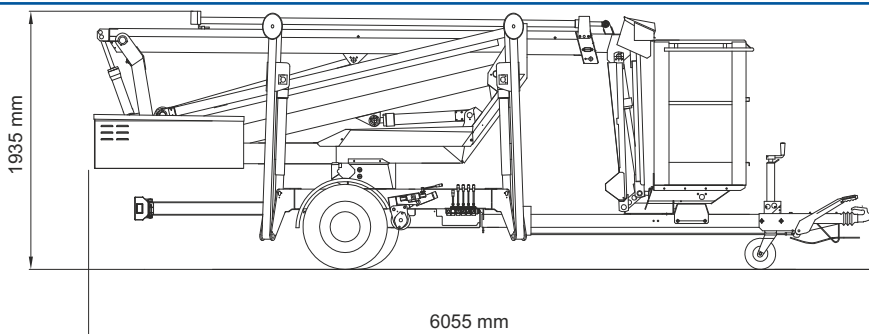
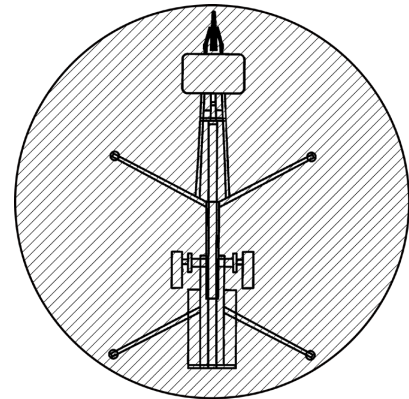
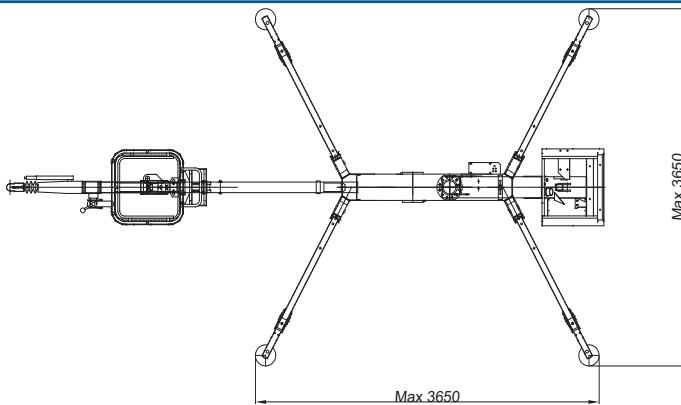

03.22 Subject to change without notice. Data, dimensions and features are indicative and not binding



Chennai | Bengaluru | Mumbai | Ahmedabad | Hyderabad | Delhi | Kolkata | Sri Lanka | Qatar

equipment@mtandt.com | 9090 1010 65 | www.mtandt.com