

SNORKEL
SL26RTE/SL30RTE
ELECTRIC SPEED LEVEL



- Lithium-ion electric Speed Level sigma lift
- Quiet and clean zero emissions
- Fully charged in 5-8 hours
- Climbs gradients of up to 50%
- Auto-levelling without the need for stabilizers

SNORKEL

SL26RTE/SL30RTE

ELECTRIC SPEED LEVEL



DIMENSIONS	SL26RTE	SL30RTE
Max. working height	10.0m	11.0m
Max. platform height (A)	8.0m	9.0m
Platform size (stowed)	1.72m x 3.66m	1.72m x 4.23m
Platform size (extended) (E)	1.72m x 4.6m	n/a
Extension deck length	0.91m	n/a
Overall width (D)	2.13m	2.13m
Overall length (C)	3.79m	4.3m
Stowed height (B)	2.6m	2.6m
Min. height (guardrails folded)	1.7m	1.7m
Chassis ground clearance	305mm	305mm
Axle ground clearance	195mm	195mm

PERFORMANCE	SL26RTE	SL30RTE
Platform capacity (SWL)	680kg	590kg
Max. wind speed	12.5m/s	12.5m/s
Max. drive height	8.0m	9.0m
Max. drive speed (stowed)	5.4 km/h	5.4 km/h
Max. drive speed (elevated)	0.8km/h	0.8km/h
Raise/lower time	21/32 seconds	24/36 seconds
Gradeability	50%	50%
Max. levelling, front to rear	9°	9°
Max. levelling, side to side	13°	13°
Inside turning radius	3.9m	3.9m
Outside turning radius	5.64m	5.64m
Tyres	26 x 12.00 - 12 foam filled	
Controls	digital proportional joystick	
Drive system	4 wheel drive with hydraulic motors and flow dividers	

POWER	SL26RTE	SL30RTE
Power source	Li-ion batteries with integrated BMS	
Operating temperature	(-)25°C to (+)60°C (-)25°C to (+)60°C	
Charger	high frequency smart on-board 50A battery charger	

MOTOR	SL26RTE	SL30RTE
Motor	AC electric motor	

WEIGHT	SL26RTE	SL30RTE
Weight	3,500kg	3,450kg

LEVELLING CAPABILITIES

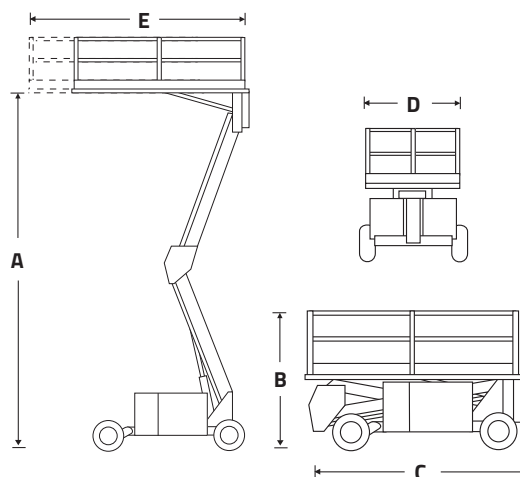
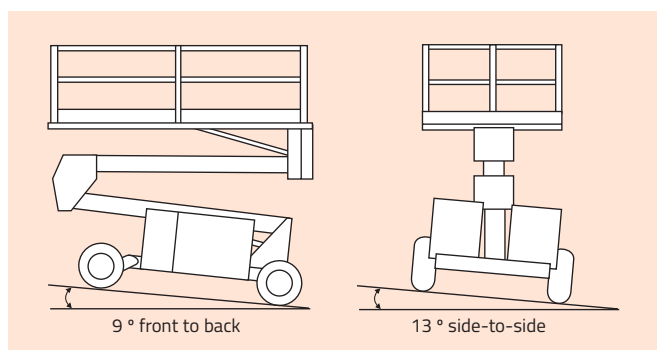

STANDARD FEATURES

- Two lithium-ion battery systems 11.5kWh
- Automatic powered platform levelling
- Powerful 4 wheel drive
- Oscillating front axle
- High grip, open tread deck (SL30RTE only)
- Roll-out deck extension (SL26RTE only)
- Descent alarm
- High grip non-marking all terrain tyres
- Digital proportional controls
- Power line to platform
- Fold-down guardrails
- All motion alarm
- Hour meter & on-board diagnostics display
- Flashing amber light
- 2000 charging cycles / 2 year* lithium battery warranty
- 2 year parts & labour, 5 year structural warranty

OPTIONS

- Special paint colours
- Environmental hydraulic oil
- Additional 5.75kWh battery system
- Tunnel package (23kWh)
- Extra range tunnel package (23kWh)
- Work light package
- Driving light package
- Extreme environment package
- Aluminium platform floor (SL26RTE only)

CE Specification
© Snorkel 2020

Specifications subject to change without notice. Photos and diagrams in this brochure are for promotional purposes only. Refer to appropriate Snorkel operators manual for detailed instructions on the proper use and maintenance. *whichever comes first. Refer to Snorkel warranty policy for full details, limitations and restrictions. Batteries at the end of their life to be returned to Snorkel for recycling.