

SNORKEL

S2770BE/S3370BE/S3970BE

COMPACT BI-ENERGY ROUGH TERRAIN SCISSOR LIFT



- Compact bi-energy scissor lifts
- Suitable for interior and exterior use
- Non-marking, high grip tyres
- Easy to operate
- Ideal for construction sites

SNORKEL

S2770BE/S3370BE/S3970BE

COMPACT BI-ENERGY ROUGH TERRAIN SCISSOR LIFT



DIMENSIONS	S2770BE	S3370BE	S3970BE
Max. working height	10.1m	12.0m	13.8m
Max. platform height (A)	8.1m	10.0m	11.8m
Platform size (stowed) (B)	1.6m x 2.8m	1.6m x 2.8m	1.6m x 2.8m
Platform size (extended) (C)	1.6m x 4.0m	1.6m x 4.0m	1.6m x 4.0m
Extension deck length	1.2m	1.2m	1.2m
Overall width (D)	1.8m	1.8m	1.8m
Stowed length (E)	3.4m	3.4m	3.4m
Stowed height (F)	2.61m	2.7m	2.95m
Min. height (guardrails folded)	1.83m	2.0m	2.13m
Ground clearance	330mm	330mm	330mm

PERFORMANCE	S2770BE	S3370BE	S3970BE
Platform capacity (SWL)	580kg	450kg	350kg
Max. drive height	8.1m	10.0m	11.8m
Max. wind speed	12.5m/s	12.5m/s	12.5m/s
Max. drive speed (stowed)	4.5km/h (engine)		
Max. drive speed (elevated)	0.5km/h (engine)	0.3km/h (engine)	0.3km/h (engine)
Raise/lower time	50/47 sec (engine) 65/47 sec (battery)		
Gradeability (engine)	35%	30%	30%
Gradeability (battery)	25%	25%	25%
Max. outrigger levelling, front to rear	6°	6°	6°
Max. outrigger levelling, side to side	10°	10°	10°
Inside turning radius	2.7m	2.7m	2.7m
Outside turning radius	5.0m	5.0m	5.0m
Tyres	27 x 10.5 foam filled, non-marking		
Controls	proportional joystick		
Drive system	4 wheel drive		

POWER	S2770BE	S3370BE	S3970BE
Power source	Kubota D-902 water cooled diesel 22.5hp and 4 x 6v 305Ah batteries		

WEIGHT	S2770BE	S3370BE	S3970BE
Weight	3,099kg	3,919kg	4,090kg

TURNING RADIUS

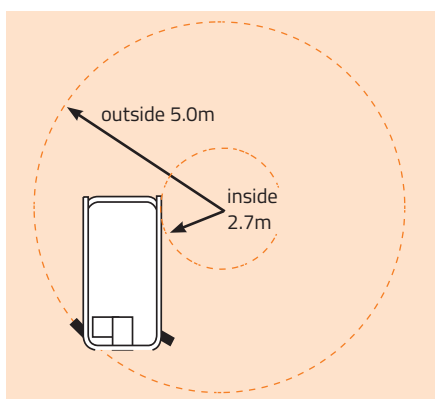

CE Specification
© Snorkel 2020

Specifications subject to change without notice. Photos and diagrams in this brochure are for promotional purposes only. Refer to appropriate Snorkel operators manual for detailed instructions on the proper use and maintenance.

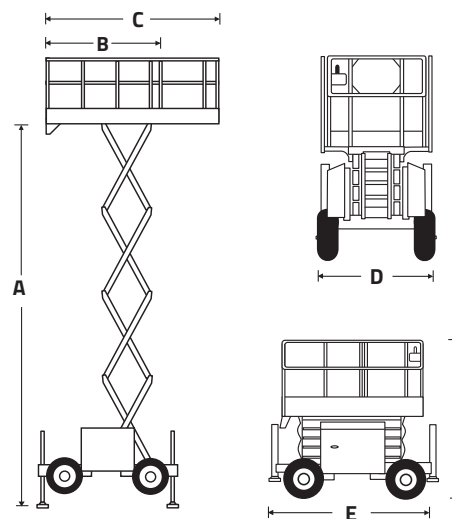

STANDARD FEATURES

- DC and diesel power - for indoor & outdoor work
- 4 wheel drive
- 4 hydraulic outriggers with automatic levelling
- Roll-out deck extension
- Non-marking foam filled tyres
- Proportional controls
- Flashing amber light
- Articulated axle
- Power line to platform
- Drive motion alarm
- Descent alarm
- Fold-down guardrails
- Hour meter & on-board diagnostics display
- Dual lanyard attachment points
- Manual lowering valve
- 2 year parts & labour, 5 year structural warranty
- CE approved

OPTIONS

- Special paint colours
- Hydraulic generator 110V/240V
- Nylon spreader pads (set of 4)
- Environmental hydraulic oil



Delivering Safety & Productivity

Chennai | Bengaluru | Mumbai | Ahmedabad | Delhi | Kolkata | Sri Lanka | Qatar

equipment@mtandt.com | 90901 01065 | www.mtandt.com