

SNORKEL

S9056RT-HC/S9070RT-HC

ULTRA HIGH CAPACITY ROUGH TERRAIN SCISSOR LIFT



- Ultra high capacity, large deck rough terrain scissor lifts
- Excellent rough terrain performance
- Heavy duty design
- Dual powered extension decks
- Ideal for construction applications

SNORKEL

S9056RT-HC/S9070RT-HC

ULTRA HIGH CAPACITY ROUGH TERRAIN SCISSOR LIFT



DIMENSIONS	S9056RT-HC*	S9070RT-HC*
Max. working height	19.1m	23.3m
Max. platform height (A)	17.1m	21.3m
Platform size (stowed)	2.28m x 4.87m	
Platform size (dual deck extended)	2.28m x 8.23m	
Extension deck length	1.37m	1.37m
Overall width (B)	2.28m	2.28m
Overall length (C)	4.87m	4.87m
Stowed height (D)	3.09m	3.43m
Min. height (guardrails folded)	2.1m	2.5m
Ground clearance	356mm	356mm

PERFORMANCE	S9056RT-HC*	S9070RT-HC*
Platform capacity (SWL)	1,134kg	907kg
Max. drive height	9.4m	9.4m
Max. wind speed	12.5m/s	12.5m/s
Max. drive speed (stowed)	6.7km/h	6.7km/h
Max. drive speed (elevated)	0.96km/h	0.96km/h
Raise/lower time	55/35 sec	70/40 sec
Gradeability	50%	50%
Max. stabilizer levelling, front to rear	6°	6°
Max. stabilizer levelling, side to side	14°	14°
Inside turning radius	2.4m	2.4m
Outside turning radius	5.6m	5.6m
Tyres	13 x 36 foam filled	
Controls	proportional joystick	
Drive system	4 wheel drive	

POWER	S9056RT-HC*	S9070RT-HC*
Power source	Kubota diesel	

WEIGHT	S9056RT-HC*	S9070RT-HC*
Weight	9,072kg	11,566kg

TURNING RADIUS

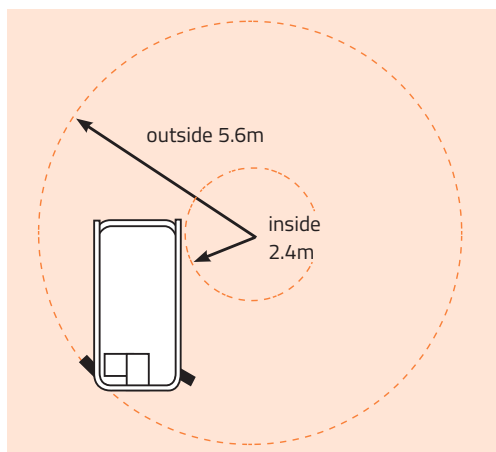

CE Specification
© Snorkel 2020

Specifications subject to change without notice. Photos and diagrams in this brochure are for promotional purposes only. Refer to appropriate Snorkel operators manual for detailed instructions on the proper use and maintenance. Preliminary specifications – confirm at time of ordering.

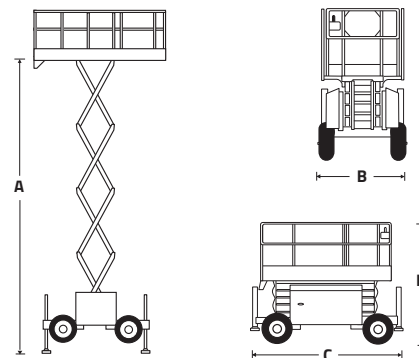

STANDARD FEATURES

- 4 wheel drive
- 4 hydraulic stabilizers with automatic levelling
- Dual powered extension decks
- Proportional controls
- Foam filled tyres
- Power line to platform
- Drive motion alarm
- Descent alarm
- Locking articulating axle
- Manual lowering valve
- Flashing amber light
- Dual lanyard attachment points
- Hour meter & on-board diagnostics display
- 2 year parts & labour, 5 year structural warranty
- CE approved

OPTIONS

- Special paint colours
- Nylon spreader pads (set of 4)
- Environmental hydraulic oil
- Dual fuel
- LPG power
- Cold weather package (block heater + battery warm up)
- Hydraulic 2kW generator
- Hydraulic 12kW generator



Delivering Safety & Productivity

Chennai | Bengaluru | Mumbai | Ahmedabad | Delhi | Kolkata | Sri Lanka | Qatar

equipment@mtandt.com | 90901 01065 | www.mtandt.com