

SNORKEL
SL26RT/SL30RT
DIESEL SPEED LEVEL



- The original Speed Level sigma lift
- Climbs gradients of up to 50%
- Auto-levelling without the need for outriggers
- Suitable for most terrains
- Powerful 4x4 drive
- Ideal for rough terrain or work at height on sloped ground

SNORKEL

SL26RT/SL30RT

DIESEL SPEED LEVEL



DIMENSIONS	SL26RT	SL30RT
Max. working height	10.0m	11.0m
Max. platform height (A)	8.0m	9.0m
Platform size (stowed)	1.72m x 3.66m	1.72m x 4.23m
Platform size (extended) (B)	1.72m x 4.6m	n/a
Extension deck length	0.91m	n/a
Overall width (C)	2.13m	2.13m
Overall length (D)	3.79m	4.3m
Stowed height (E)	2.6m	2.6m
Min. height (guardrails folded)	1.7m	1.7m
Chassis ground clearance	305mm	305mm
Axle ground clearance	195mm	195mm

PERFORMANCE		
Platform capacity (SWL)	680kg	590kg
Max. drive height	8.0m	9.0m
Max. wind speed	12.5m/s	12.5m/s
Max. drive speed (stowed)	6.4km/h	6.4km/h
Max. drive speed (elevated)	0.8km/h	0.8km/h
Raise/lower time	21/32 sec	24/36 sec
Gradeability	50%	50%
Max. levelling, front to rear	9°	9°
Max. levelling, side to side	13°	13°
Inside turning radius	3.9m	3.9m
Outside turning radius	5.64m	5.64m
Tyres	26 x 12.00 - 12 foam filled	
Controls	proportional joystick	
Drive system	4 wheel drive with hydraulic motors and flow dividers	

POWER	
Power source	Kubota D-902 water-cooled diesel Tier 4 Final

WEIGHT		
Weight	3,500kg	3,400kg

LEVELLING CAPABILITIES

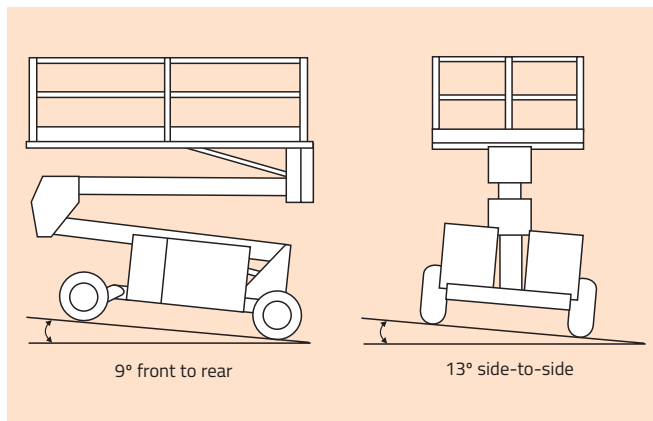

CE Specification
© Snorkel 2020

Specifications subject to change without notice. Photos and diagrams in this brochure are for promotional purposes only. Refer to appropriate Snorkel operators manual for detailed instructions on the proper use and maintenance.

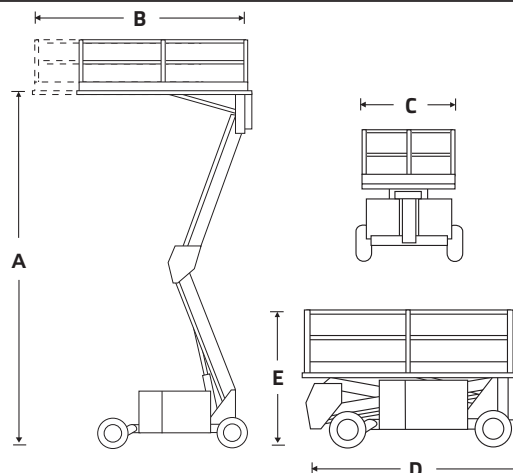

STANDARD FEATURES

- Automatic powered platform levelling
- Powerful 4 wheel drive
- Oscillating front axle
- High grip, open tread deck (SL30RT)
- Roll-out deck extension (SL26RT)
- Descent alarm
- High grip all-terrain tyres
- Dual multi-disc brakes
- Proportional controls
- Power line to platform
- Fold-down guardrails
- All motion alarm
- Flashing amber light
- Hour meter & on-board diagnostics display
- Horn
- 2 year parts & labour, 5 year structural warranty
- CE approved

OPTIONS

- Special paint colours
- Diesel exhaust scrubber
- Environmental hydraulic oil
- Hydraulic generator 110V/240V 3.5kW
- Tunnel package
- Non-marking tyres
- Aluminum platform floor (SL26RT only)



Delivering Safety & Productivity

Chennai | Bengaluru | Mumbai | Ahmedabad | Delhi | Kolkata | Sri Lanka | Qatar

equipment@mtandt.com | 90901 01065 | www.mtandt.com